

ITEM	DESCRIPTION
1	POWER CORD
2	DISPLAY SCREEN
3	CO2 SAMPLE PORT
4	ACCESS PORT 1-1/8" [28.6mm]
5	USB CONNECTION PORT COVER
6	ON / OFF SWITCH
7	CIRCUIT BREAKER
8	AC POWER CORD CONNECTION
9	CO2 INLET
10	AIR FILTER
11	CO2 FILTER
12	4 - 20 MA CONNECTION
13	RS-485 CONNECTION
14	REMOTE ALARM CONNECTION
15	AIR SUPPLY INLET
16	N2 INLET
17	N2 SUPPLY FILTER
18	RH TANK
19	PORT PLUG: MODELS W/O HEATED DECON
20	SILICON PORT PLUG: MODELS W/HEATED DECON
21	SENSOR BAY ACCESS PANEL
22	USB PORT - FRONT

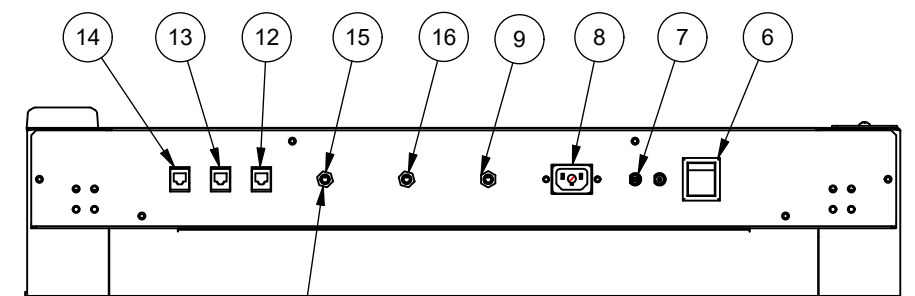

REV	ECO	DESCRIPTION	DATE	DFTM	CHKD
A	13712	UPDATED USB PORTS, ADDED CAUTION LABEL TO FRONT VIEW	4/2/2018	TH	KCK

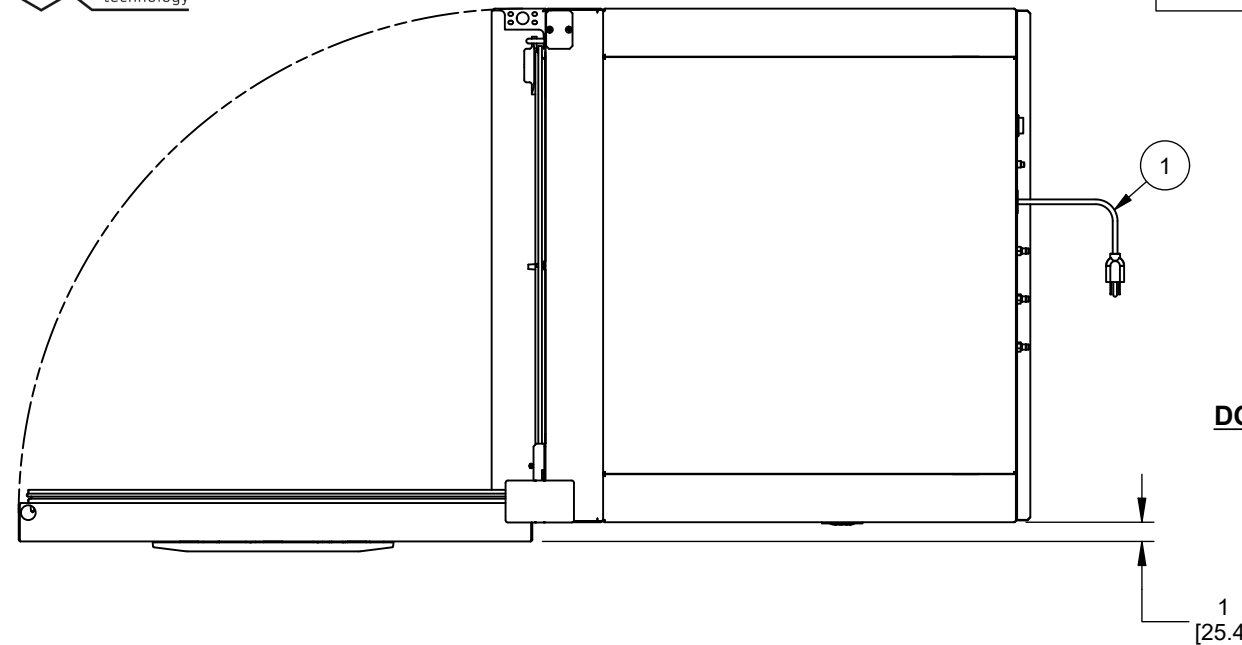

DO NOT PLUG OR INSTALL PRESSURIZED SOURCE

VIEW A-A

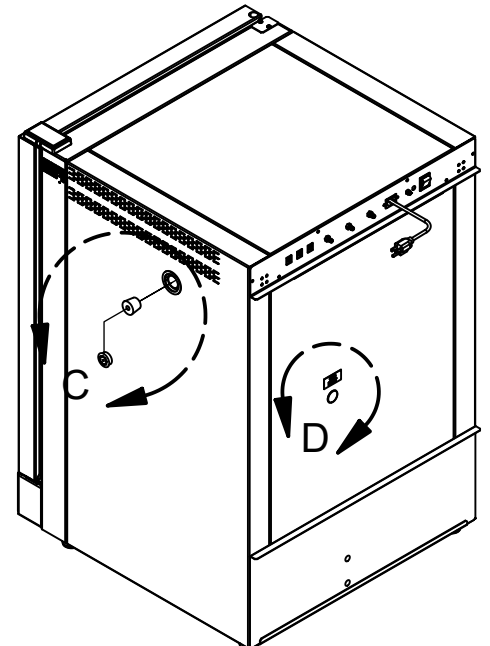

EXTERIOR DIMENSIONS
 39.688" [1008.1mm] H
 26.750" [679.5mm] W
 27.500" [698.0mm] D

INTERIOR DIMENSIONS
 28.500" [723.9mm] H
 21.257" [539.9mm] W
 20.053" [509.3mm] D

SHELF DIMENSIONS
 19.250" [489.0mm] W
 18.750" [476.3mm] D

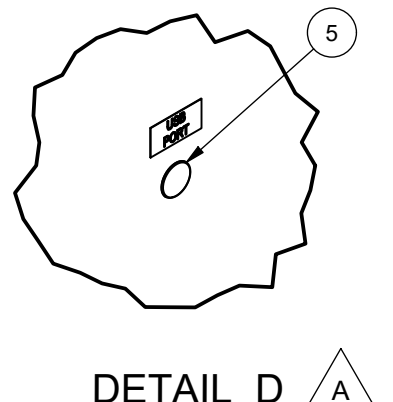
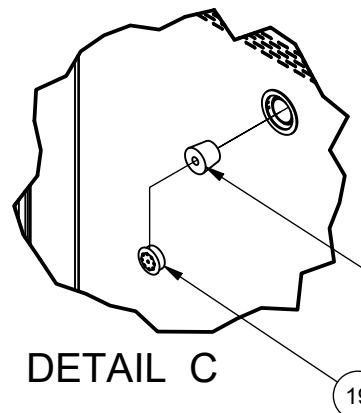
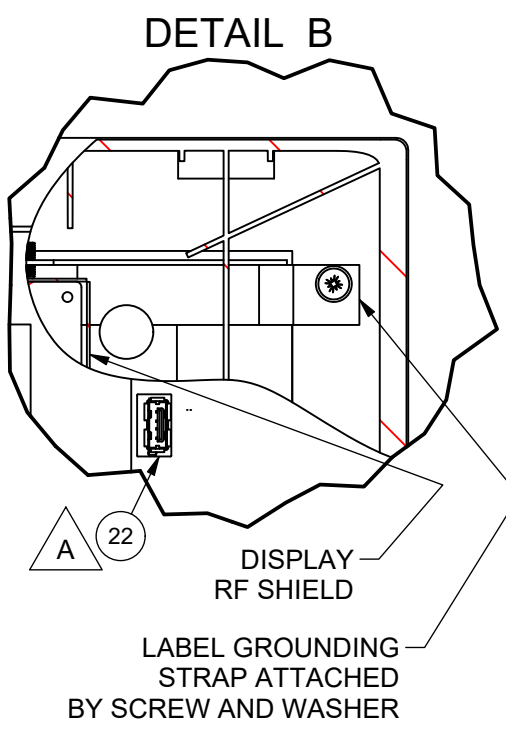
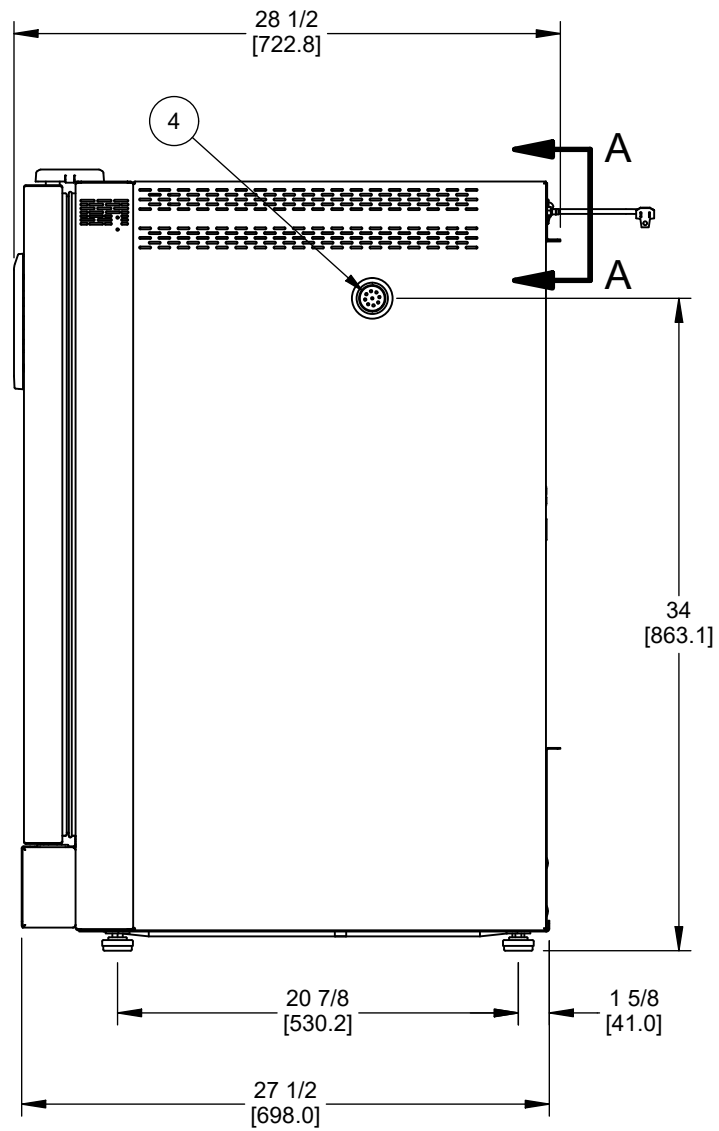
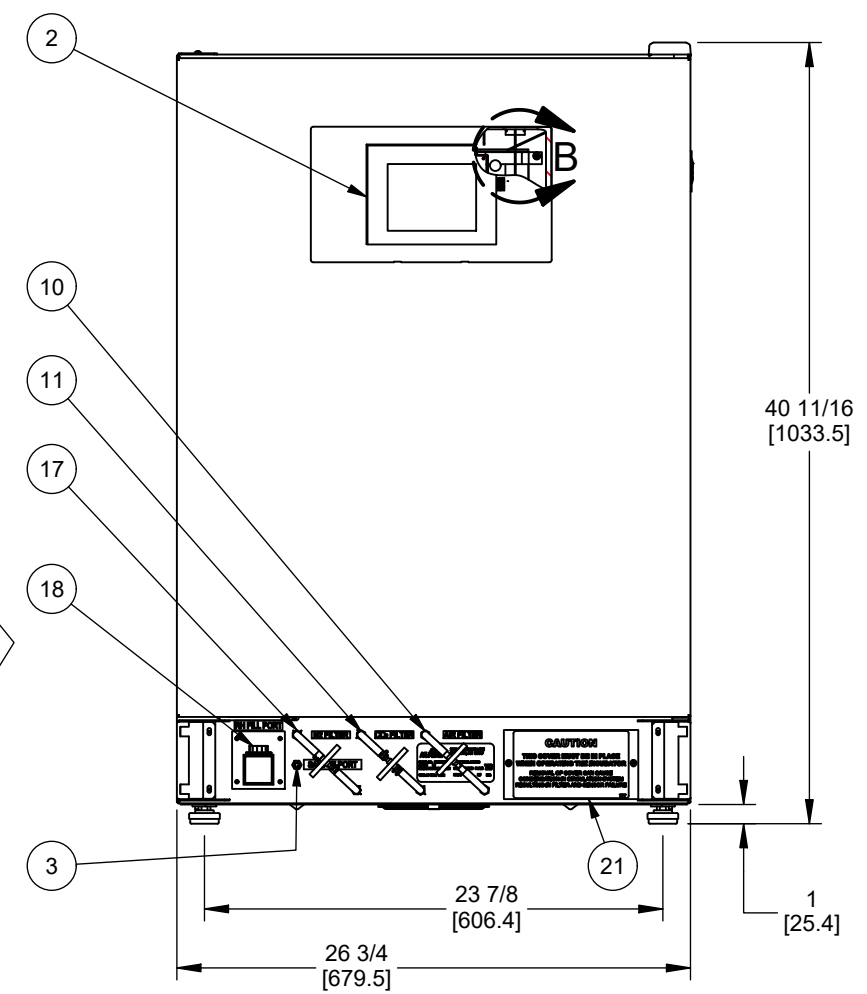

TITLE ASSEMBLY, NU-5800					
DFTM LS	DATE 6/7/2016	CHKD KCK	SHEET 1	OF 1	
DRAWING NUMBER BCD-18314					D