

CTR-6 CO₂ Tube Roller



If you have any feedback on our products or services, we would like to hear from you.
Please send all feedback to:

Manufacturer:

SIA Biosan
Ratsupites 7 k-2, Riga, LV-1067, Latvia

Phone: +371 674 261 37

Fax: +371 674 281 01

<https://biosan.lv>

Marketing: marketing@biosan.lv

Service: service@biosan.lv

Contents

1.	About this edition of user instructions.....	3
2.	Safety precautions	4
3.	General information.....	6
4.	Getting started.....	7
5.	Operation	10
6.	Specifications	11
7.	Ordering information	12
8.	Care and maintenance	13
9.	Storage and transportation.....	13
10.	Warranty and registration	14
11.	EU Declaration of Conformity.....	15

1. About this edition of user instructions

1.1 The current edition of the user instructions applies to the following models:

Model and name	Version
CTR-6, CO ₂ tube roller	V.1AW

1.2 Edition 1.01 – March of 2023

2. Safety precautions

2.1 Symbols used in these instructions:



Caution! Make sure you have fully read and understood the present instructions before using the equipment. Please pay special attention to sections marked by this symbol.

2.1 Icons used on the unit and packaging:

	CE marking, manufacturer affirms conformity with European health, safety, and environmental protection standards, see 11.1
	WEEE directive marking, see 11.1

2.2 General safety

- Save the unit from shocks or falling.
- Store and transport the unit as described in **Storage and transportation**.
- Before using any cleaning or decontamination methods except those recommended by the manufacturer, check with the manufacturer that the proposed method will not damage the equipment.
- Do not make modifications in design of the unit.
- The protection provided by the equipment may be impaired if the equipment is used with accessories not provided or recommended by the manufacturer or used in a manner not specified by the manufacturer.

2.3 Electrical safety

- Connect only to external power supply with voltage corresponding to that on the serial number label.
- Use only the external power supply provided with this product.
- Ensure that the external power supply is easily accessible during use.
- Disconnect the unit from the mains before moving.
- Turn off the unit by disconnecting the external power supply from the power socket.
- If liquid penetrates into the unit, disconnect it from the power socket and have it checked by a repair and maintenance technician.
- Do not operate the unit in premises where condensation can form. Operating conditions of the unit are defined in section **Specifications**.

2.4 During operation

- Hazards may occur if the equipment is used to mix flammable or explosive materials.
- Do not mix materials where the transfer of mechanical energy to glass could lead to a breakage.
- Do not use the equipment in hazardous atmospheres or with hazardous materials for which the equipment is not designed.
- Do not impede the platform motion.
- Do not operate the unit in environments with aggressive or explosive chemical mixtures. Please contact manufacturer for possible operation of the unit in specific atmospheres.
- Do not operate the unit if it is faulty or has been installed incorrectly.
- Do not use outside laboratory rooms.
- Do not place a load exceeding the maximum load value mentioned in section **Specifications**.

2.5 Biological safety

- It is the user's responsibility to carry out appropriate decontamination if hazardous material is spilt on or penetrates into the equipment.

3. General information

CO₂ Tube Roller **CTR-6** provides regulated rocking and rolling of maximum up to 6 rollers and is designed for use specifically in CO₂ incubators. CTR-6 is specifically designed for use in harsh environments such as CO₂ and humidity and provides reproducible results for cell culture growth. Possibility to remove rollers makes the unit flexible and allows for performing various procedures and techniques in various cultivation vessels. The specially designed remote controller allows for protection of electronics from CO₂ incubator environment, as well as does not interfere with the experiment.

Tube roller **CTR-6** incorporates a stepper motor with a guaranteed service life up to 10000 hours. It is possible to stack up to 2 units, saving valuable bench space. Typical applications include cells cultivation (eukaryotic, microbial) and general mixing (resuspension, viscous and liquid-solid suspensions).

4. Getting started

4.1 **Unpacking.** Remove packing materials carefully and retain them for future shipment or storage of the unit. Examine the unit carefully for any damage incurred during transit. The warranty does not cover in-transit damage. Warranty covers only the units transported in the original package.

4.2 **Complete set.** Package contents:

4.2.1 Standard set

- **CTR-6** Tube roller 1 pce.
- External power supply 1 pce.
- Remote controller 1 pce.
- Operating instructions, declaration of conformity 1 copy

4.2.2 Optional accessories, on request

- Rubber O-rings 1 set
- Stacking kit for two units 1 set
- Stacking kit for three units 1 set
- Roller 1 pce.

4.3 **Roller installation.** Install the roller (fig. 1/1) to the base mechanism of the rolling unit. Open the back fixation plate (fig. 1/2) by unscrewing both screws (fig. 1/3). Fit the roller on the mechanism shaft (fig. 1/4). The roller must be carefully aligned with other rollers horizontally. Close the fixation plate.

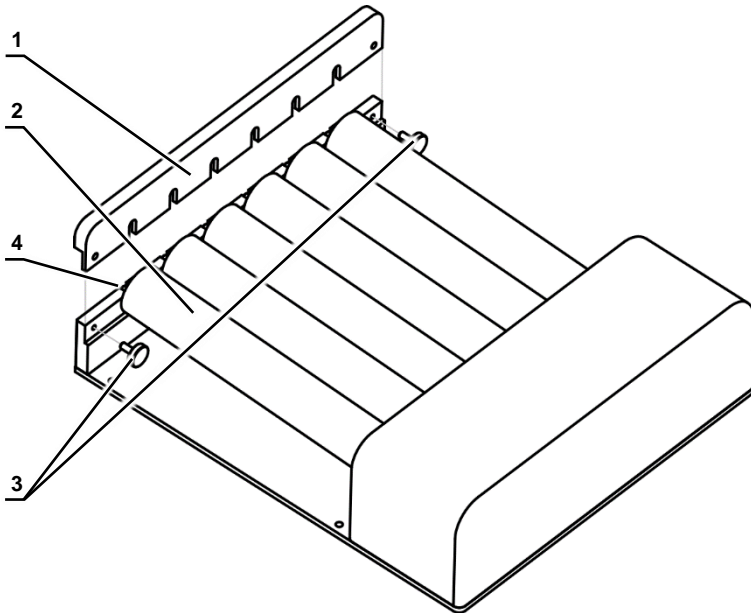

Figure 1. Roller installation

4.4 Stacking.

4.4.1 Stacking kit contains:

Component	Kit for 2 units	Kit for 3 units
Catalogue number	BS-010174-BK	BS-010174-CK
Connecting rods	4	8
Holder bracket	8	12
Headless hex socket screw (M4)	–	4
Hex screw (M4x8 mm)	16	24
Washer (M4)	16	24

4.4.2 **Acquiring a kit.** To purchase the kit, contact Biosan or your local Biosan representative, with information from the section **Ordering information**.

4.4.3 Getting started.

- Unpack the kit. Unpower and unload the units and disconnect the power cables.
- Prepare the working space. Ensure that there are no obstacles, there is enough space, the surface is clear and clean.
- Position the units so that the access to the mains plugs, the sockets and the power switches is unobstructed.

4.4.4 Stacking two units (figure 2).

- Lock the bracket parts (fig. 2/1) with hex screws and washers (fig. 2/2) in 4 positions on the base plate of all stacking units.
- Insert the connecting rod (fig. 2/3) on the bottom bracket and secure it tightly with a hex screw and a washer. Repeat for other connecting rods.
- Place the second unit on top of the first-level rods, insert and secure the screws and washers.
- Connect the power cables to the units and to grounded mains sockets.

4.4.5 Stacking three units.

- Lock the bracket parts (fig. 2/1) with hex screws and washers (fig. 2/2) in 6 positions on the base plate of all stacking units.
- Insert the connecting rod (fig. 2/3) on the bottom bracket and secure it tightly with a hex screw and a washer. Repeat for other connecting rods.
- Screw in the headless hex socket screws into the first-level connecting rods.
- Place the second unit on top of the first unit, aligning the headless screws and brackets of the second unit.
- Screw the connecting rod onto the headless screw, securing rods and the bracket. Repeat for other connecting rods.
- Place the third unit on top of the second-level rods, insert and secure the screws and washers.
- Connect the power cables to the units and to grounded mains sockets.

4.4.6 **Maintenance.** Check the screw fixation and unit stack stability once a month.

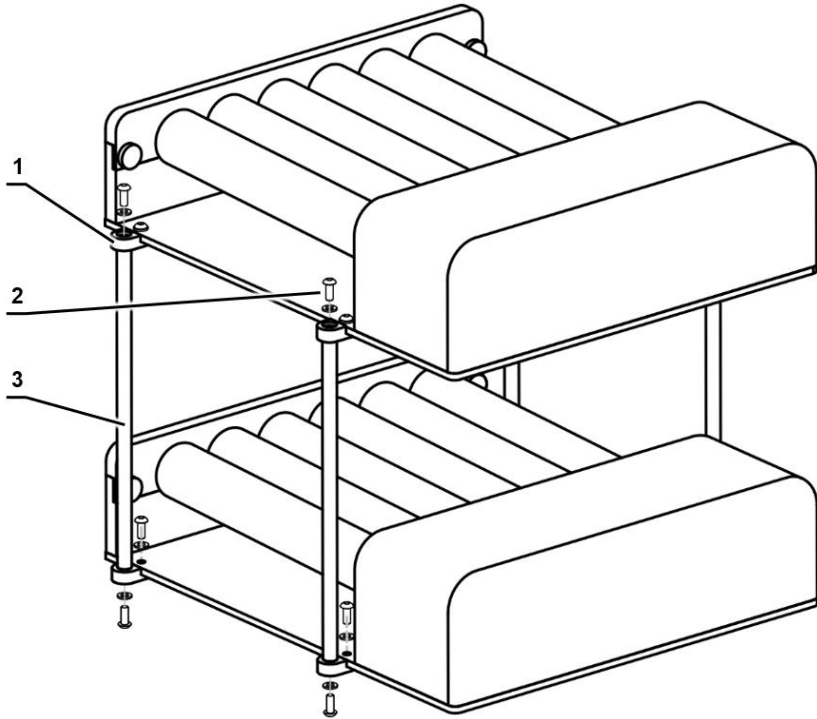

Figure 2. Stacking kit installation

4.5 Setup.



Note. The CO₂ incubator must be not operating, switched off and in non-condensing environment during the installation of CO₂ tube roller.

- Gently pull the control cable apart at the middle connector by pressing on clips.
- Thread the control cable of the shaking unit through the opening port in the CO₂ incubator.
- Place the shaking unit inside a CO₂ incubator positioned on an even horizontal and firm surface place. Make sure that the control cable does not obstruct the movement of the platform.
- Accurately connect the control cable in the middle. Align ends by the white marking on the rim. Do not force the connection.
- Remove protective film from the display.
- Plug the external power supply into the 12 V socket at the bottom of the unit controller and position the power supply so that the plug is easily accessible.
- If necessary, install the unit controller on the outer wall or a door of the CO₂ incubator. The unit controller features magnets on the back.



Figure 3. Stacked units

5. Operation

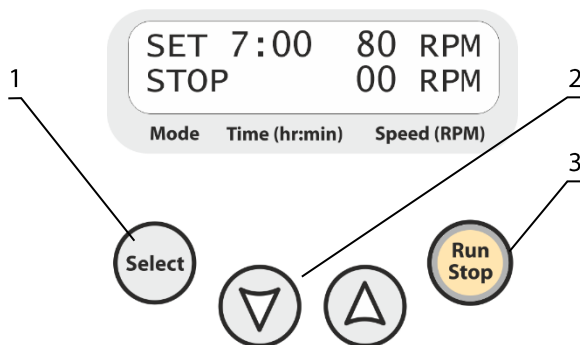

Figure 4. Control panel of CTR-6

- 5.1 Connect the external power supply to the mains. Switch the power switch on the rear side of the unit into position **I** (on).
- 5.2 Place samples on the unit platform.
- 5.3 **Setting the parameters.** Press the **Select** key (fig. 4/1) to choose the parameter to change. Each pressing of the **Select** key consecutively activates the parameters. The active parameter is flashing. Use the ▼ and ▲ keys (fig. 4/2) to set the necessary value. Pressing the key for more than 2 s increases the speed of value change.
 - 5.3.1 Set the required working time interval in hours and minutes, the increment is 1 minute.
 - 5.3.2 Set the required shaking speed, the increment is 1 rpm.
- 5.4 Press the **Run Stop** key (fig. 4/3). The platform starts rotation, indication **RUN** appears on display and the timer in the lower line of the display starts counting the time interval.
- 5.5 After the timer reaches the set time, the platform motion will stop and the flashing indication **STOP**, accompanied by the repetitive sound signal, will appear in the lower line of the display. Press the **Run Stop** key to shut down the signal.

- 5.6 The unit can be stopped before the set time elapses, if necessary, by pressing the **Run Stop** key. Press the **Run Stop** key to repeat the operation with the same working time and speed.
- 5.7 If the working time is not set (or is reset) and the Time indicator on display shows OFF, pressing the **Run Stop** key will start continuous operation of the unit until the **Run Stop** key is pressed.
- 5.8 The platform motion can be stopped at any time by pressing the **Run Stop** key. In this case, the program realization and the platform motion will stop, and the unit will switch into the STOP mode.
- 5.9 **Power interruption.** In case of mains/power failure, the unit is not equipped with automatic restart function, which requires the user to reinitiate the platform motion manually.
- 5.10 After finishing the operation, switch the power switch on the rear side of the unit into position **O** (off) and disconnect the external power supply from the mains.

6. Specifications

The tube roller unit (without the unit controller) is designed specifically for operation in CO₂ incubators and closed laboratory environments at ambient temperature from +4°C to +45°C in a non-condensing atmosphere and relative humidity up to 98%.

The unit controller is designed for operation in cold rooms, incubators (excluding CO₂ incubators) and closed laboratory rooms at ambient temperature from +4°C to +40°C in a non-condensing atmosphere and relative humidity up to 80% for temperatures for temperatures up to 31°C decreasing linearly to 50% relative humidity at 40°C.

Both the tube roller unit and the unit controller are designed to work at altitude up to 2000 m., transient overvoltages up to the II category and pollution degree 2.

Biosan is committed to a continuous programme of improvement and reserves the right to alter design and specifications of the equipment without additional notice.

Speed control range5–80 RPM



Note. Maximum speed depends on the load on the platform and the shape of the vessels

Increment 1 RPM

Digital time setting 1 min – 96 h or non-stop

Increment 1 minute

Maximum load 3 kg

Tilt angle 4°

Dimensions, WxDxH..... 310x262x80 mm

Operating voltage and current 12 V=, 415 mA

Power consumption 5 W

External power supply input 100–240 V~, 50/60 Hz, output 12 V=

Weight, accurate within ±10% 3 kg

7. Ordering information

7.1 Models and versions available:

Mode	Version	Electric plug	Catalogue number
CTR-6, CO₂ tube roller	V.1AW	230 V~, EU plug (type C)	BS-010174-A01
		100–240 V~, Multi plug	BS-010174-A02

7.2 To inquire about or order the optional accessories, contact Biosan or your local Biosan representative.

7.2.1 Optional accessories:

Description	Catalogue number
Rubber O-ring set, different diameter	BS-010174-DK
Stacking kit for two rollers	BS-010174-BK
Stacking kit for three rollers	BS-010174-CK
Roller	BS-010174-FK

8. Care and maintenance

8.1 Service.

- 8.1.1 If the unit is disabled (e.g., no platform movement, no reaction to key presses, etc.) or requires maintenance, disconnect the unit from the mains and contact Biosan or your local Biosan representative.
- 8.1.2 All maintenance and repair operations (except listed below) must be performed only by qualified and specially trained personnel.
- 8.1.3 Operating integrity check. If the unit follows the procedure described in section **Operation**, then no additional checks are required.
- 8.1.4 If the stacking kit is used, check the screw fixation monthly.

8.2 Cleaning and disinfection.

- 8.2.1 Use mild soap and water with a soft cloth or sponge for cleaning the exterior. Rinse remaining washing solution with distilled water. Wipe dry the excess water with clean, soft cloth or sponge.
- 8.2.2 To disinfect the plastic and metal parts, use 75% ethanol or DNA/RNA removing solution (e.g., Biosan PDS-250). After disinfecting, wipe the surfaces dry.
- 8.2.3 The unit and its accessories are not autoclavable.
- 8.3 **Disposal.** Disposal of the appliance requires special precautions and must be carried out at an appropriate disposal site, separate from normal household waste. To prevent pollution of the environment, all waste resulting from the disposal of the product must be collected and disposed of in the country of use, in accordance with the applicable requirements for the handling of electronic waste.

9. Storage and transportation

- 9.1 Store and transport the unit in a horizontal position (see package label) at ambient temperatures between -20°C and +60°C and maximum relative humidity of 80%.
- 9.2 After transportation or storage and before connecting it to the electric circuit, keep the unit under room temperature for 2-3 hrs.

10. Warranty and registration

- 10.1 The Manufacturer guarantees the compliance of the unit with the requirements of Specifications, provided the Customer follows the operation, storage and transportation instructions.
- 10.2 The warranted service life of the unit from the date of its delivery to the Customer is 24 months (excluding optional accessories listed in 7.2). For extended warranty, see 10.5.
- 10.3 Warranty covers only the units transported in the original package.
- 10.4 If any manufacturing defects are discovered by the Customer, an unsatisfactory equipment claim shall be compiled, certified and sent to the local distributor address. To obtain the claim form, visit section **Technical support** on our website at link below.
- 10.5 Extended warranty. For **CTR-6**, the *Premium* class model, one year of extended warranty is available free of charge after registration, during 6 months from the date of sale. Online registration form can be found in section **Warranty registration** on our website at the link below.
- 10.6 Description of the classes of our products is available in the **Product class description** section on our website at the link below.

Technical support



biosan.lv/en/support

Warranty registration



biosan.lv/register-en

Product class description



biosan.lv/classes-en

- 10.7 The following information will be required in the event that warranty or post-warranty service comes necessary. Complete the table below and retain for your records.

Model	Serial number	Date of sale
CTR-6, CO ₂ tube roller		

11. EU Declaration of Conformity

11.1 CO₂ tube roller **CTR-6** is in conformity with the following relevant Union legislations:

LVD 2014/35/EU	LVS EN 61010-1:2011 Safety requirements for electrical equipment for measurement, control, and laboratory use. General requirements. LVS EN 61010-2-010:2015 Particular requirements for laboratory equipment for mixing and stirring.
EMC 2014/30/EU	LVS EN 61326-1:2013 Electrical equipment for measurement, control and laboratory use. EMC requirements. General requirements.
RoHS3 2015/863/EU	Directive on the restriction of the use of certain hazardous substances in electrical and electronic equipment.
WEEE 2012/19/EU	Directive on waste electrical and electronic equipment.

11.2 Declaration of Conformity is available on request.

Biosan SIA

Ratsupites 7 k-2, Riga, LV-1067, Latvia

Phone: +371 67426137 Fax: +371 67428101

<https://biosan.lv>

Edition 1.01 – March of 2023