

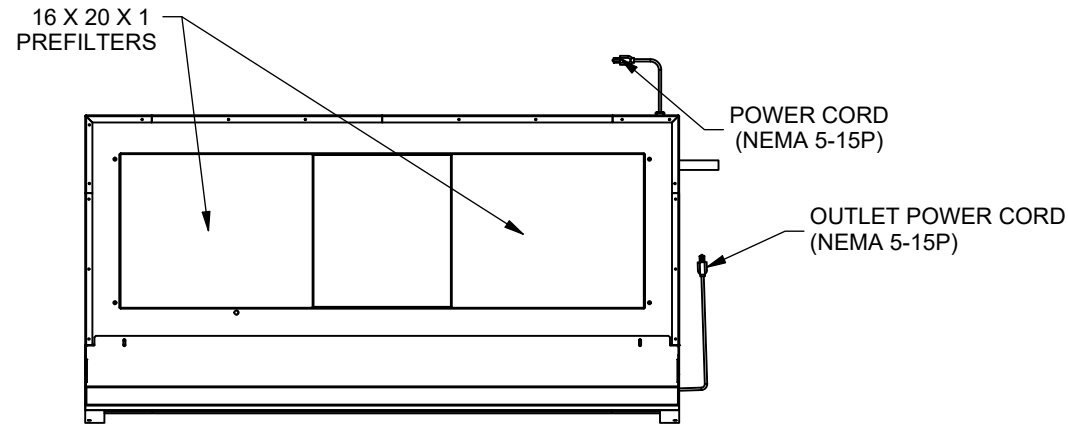

REV	ECO	DESCRIPTION	DATE	DFTM	CHKD
D	000035	UPDATED DRAWING	02/28/2019	LS	BK

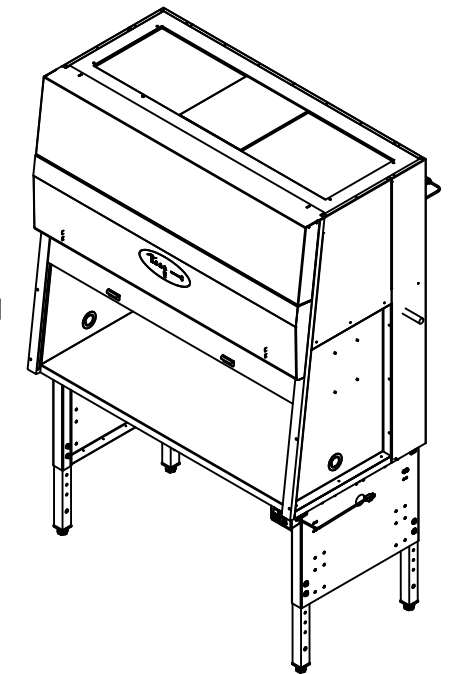

NU-140-500 BASESTAND DIMENSION OPTIONS			
BASESTAND MODEL	BASESTAND TYPE	DIM "A"	DIM "B"
NU-200-135	TELESCOPING, LEG LEVELERS	84 1/2[2146] TO 92 1/2[2350]	26 1/2[673] TO 34 1/2[876]
NU-200-139	TELESCOPING, CASTERS	84 3/4[2153] TO 92 3/4[2356]	26 3/4[680] TO 34 3/4[883]
NU-200-155 (115V) / NU-200-156 (230V)	AUTOLIFT, LEG LEVELERS	86 1/4[2191] TO 97 1/4[2471]	28 1/4[718] TO 39 1/4[997]
NU-200-157 (115V) / NU-200-158 (230V)	AUTOLIFT, CASTERS	85 7/8[2182] TO 96 7/8[2461]	27 7/8[708] TO 38 7/8[987]

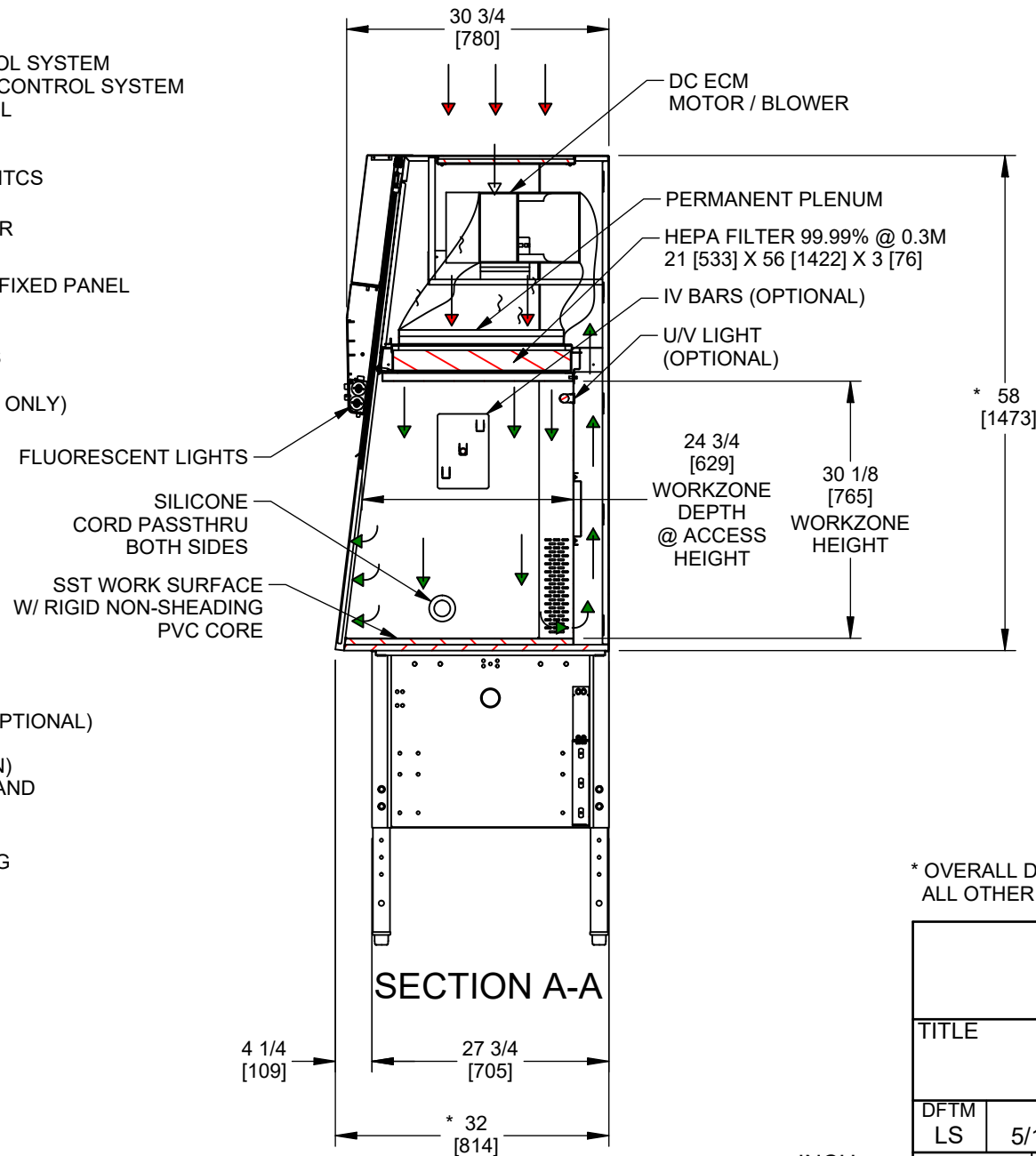
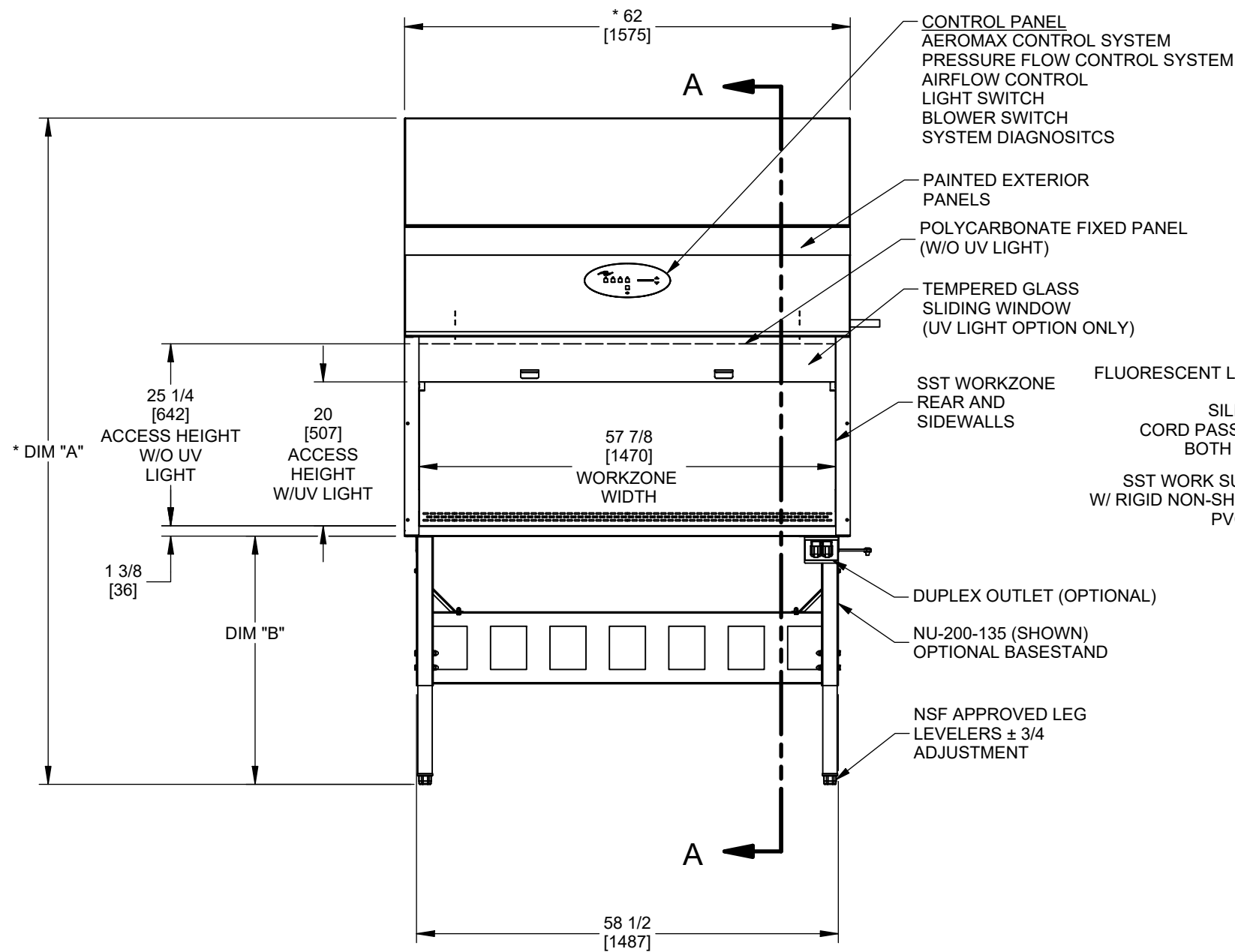

* OVERALL DIMENSIONAL TOLERANCE ±1/4" [6.35]
ALL OTHER DIMENSIONS ±1/8" [3.17]

TITLE NU-140-500 Specification Drawing					
DFTM LS	DATE 5/1/2018	CHKD BP	SHEET 1	OF 1	
DRAWING NUMBER BCD-19869		D			

INCH
MILLIMETER