

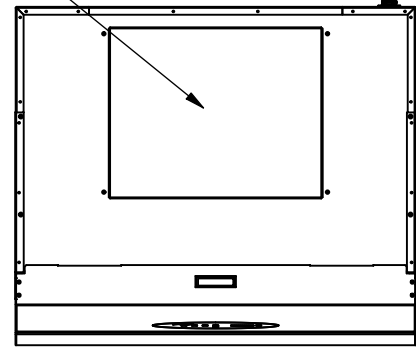

16 X 20 X 1  
PREFILTER



POWER CORD  
115V: NEMA 5-15P  
230V: SCHUKO

OUTLET POWER CORD  
115V: NEMA 5-15P  
230V: SCHUKO

REV	CO	DESCRIPTION	DATE	DFTR	CHKD
B	002148	NEW FRONT PANEL ASSY	05/15/2023	JB	LS

MODEL DIMS			
MODEL	DIM "A"	DIM "C"	HEPA FILTER SIZE
NU-240-330	32 [813]	55 1/2 [1410]	34 [864] X 30 [762] X 3 [76]
NU-240-336	38 [965]	61 1/2 [1562]	34 [864] X 36 [914] X 3 [76]

NU-240-300 BASESTAND DIMENSION OPTIONS				
BASESTAND MODEL	BASESTAND TYPE	DIM "B" (TOTAL)	DIM "D" (BASESTAND)	FILTER SIZE
NU-200-133	TELESCOPING, LEG LEVELERS	82[2083] TO 90[2286]	26 1/2[673] TO 34 1/2[876]	30"
NU-200-137	TELESCOPING, CASTERS	82 5/8[2099] TO 90 5/8[2302]	27 1/8[689] TO 35 1/8[892]	30"
NU-200-147 (115V) / NU-200-148 (230V)	AUTOLIFT, LEG LEVELERS	83 3/4[2127] TO 94 3/4[2407]	28 1/4[718] TO 39 1/4[997]	30"
NU-200-149 (115V) / NU-200-150(230V)	AUTOLIFT, CASTERS	83 3/8[2118] TO 94 3/8[2397]	27 7/8[708] TO 38 7/8[987]	30"
NU-200-133	TELESCOPING, LEG LEVELERS	88[2235] TO 96[2438]	26 1/2[673] TO 34 1/2[876]	36"
NU-200-137	TELESCOPING, CASTERS	88 5/8[2251] TO 96 5/8[2454]	27 1/8[689] TO 35 1/8[892]	36"
NU-200-147 (115V) / NU-200-148 (230V)	AUTOLIFT, LEG LEVELERS	89 3/4[2280] TO 100 3/4[2559]	28 1/4[718] TO 39 1/4[997]	36"
NU-200-149 (115V) / NU-200-150 (230V)	AUTOLIFT, CASTERS	89 3/8[2270] TO 100 3/8[2550]	27 7/8[708] TO 38 7/8[987]	36"

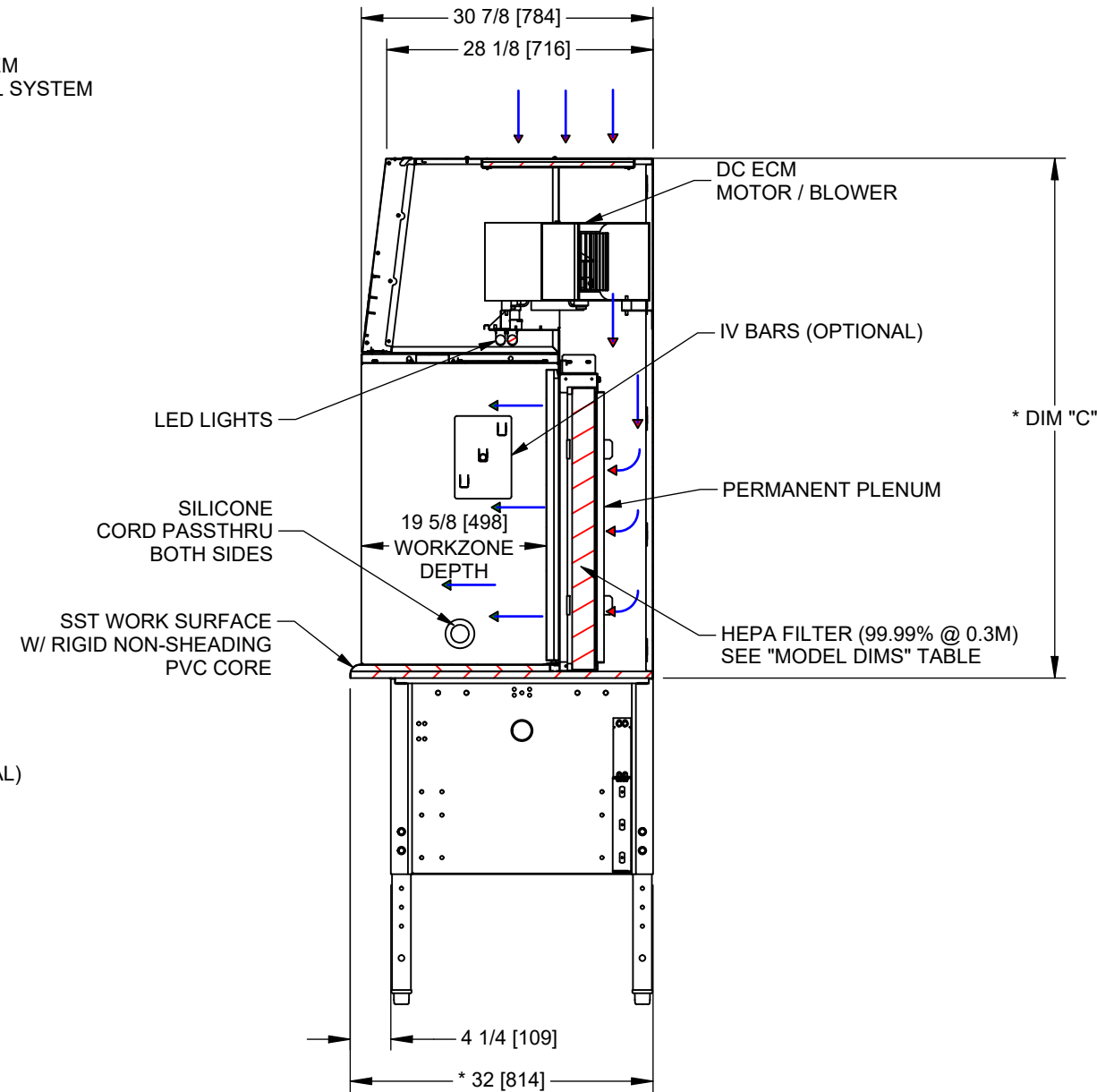
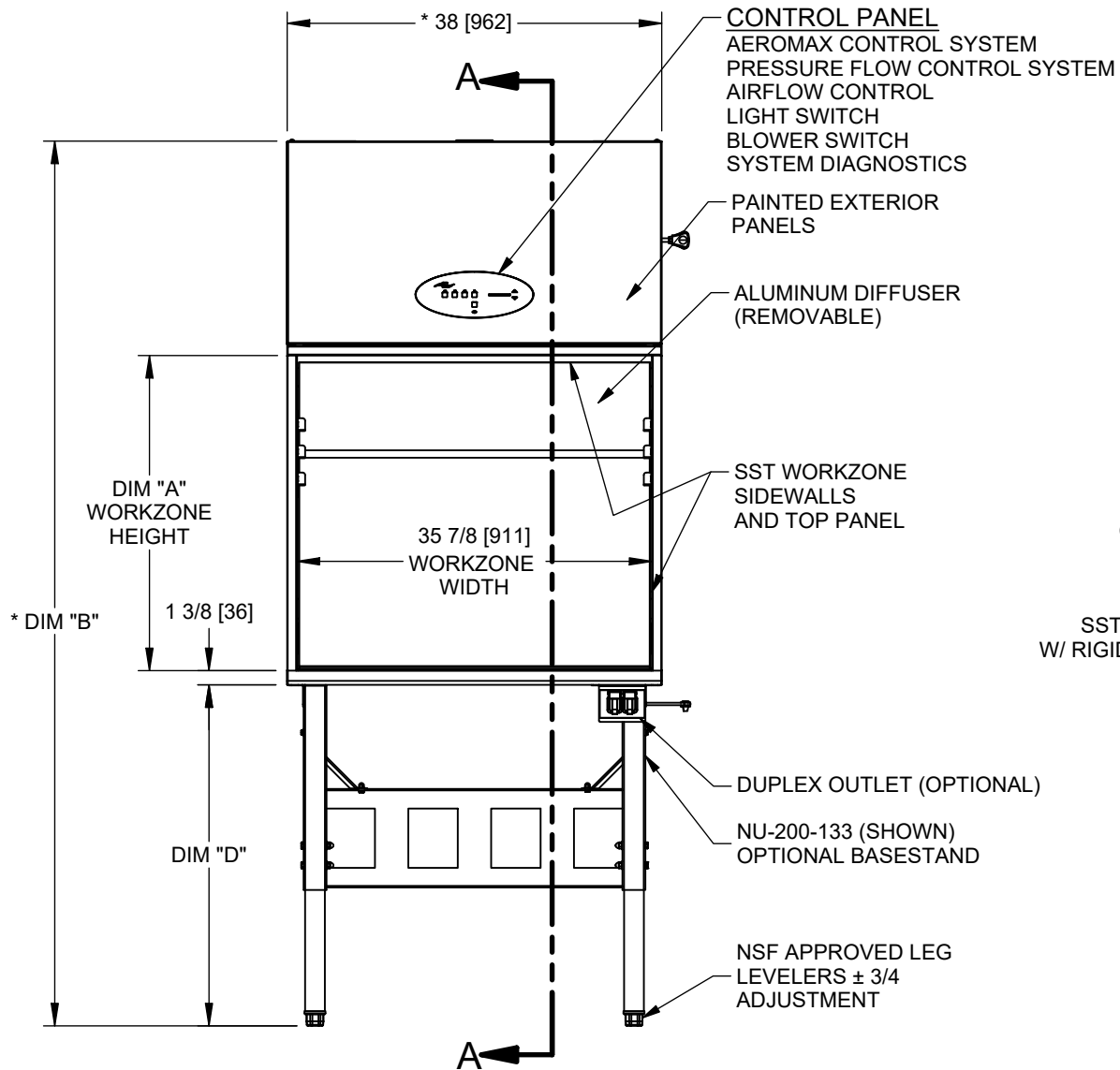

SECTION A-A

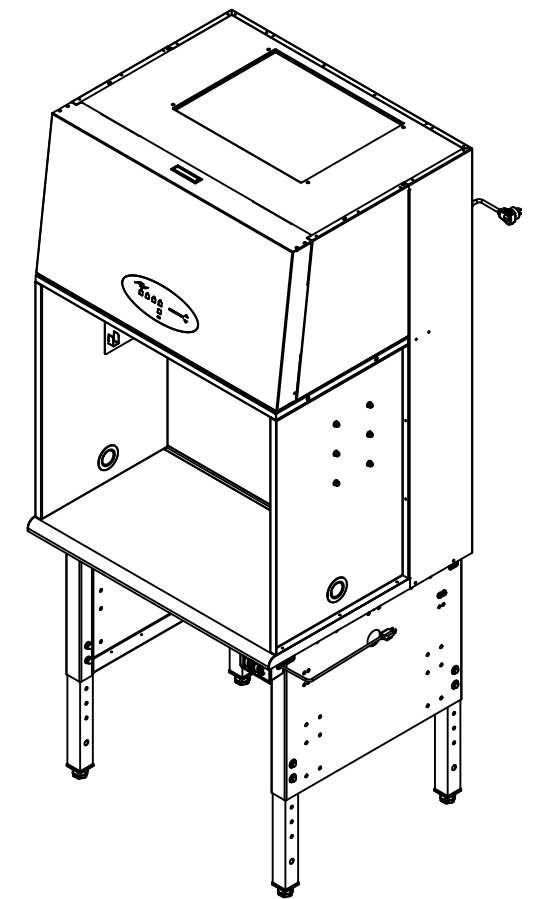

\* OVERALL DIMENSIONAL TOLERANCE ±1/4" [6.35]  
ALL OTHER DIMENSIONS ±1/8" [3.17]

INCH  
MILLIMETER

TITLE				
NU-240-300 (Series B) Spec Drawing				
DFTM	DATE	CHKD	SHEET	OF
TH	7/19/2021	BK	1	1
DRAWING NUMBER				
CD-000126-01				B