

REV	CO	DESCRIPTION	DATE	DFTR	CHKD
B	001593	ADDED NOTE	11/30/2022	RN	DF

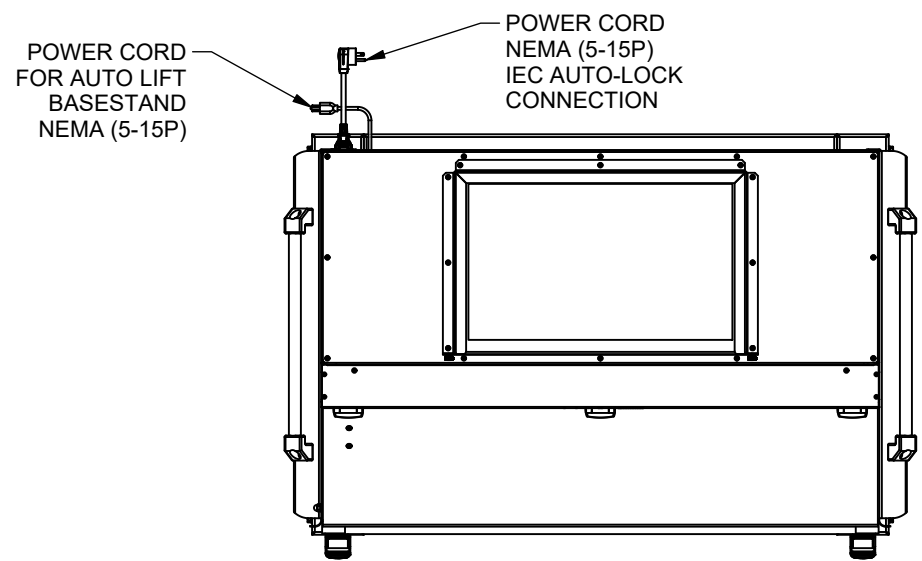

PNEUMATIC LIFT HINGED WORK SURFACE BAG ACCESS W/BANG BAR

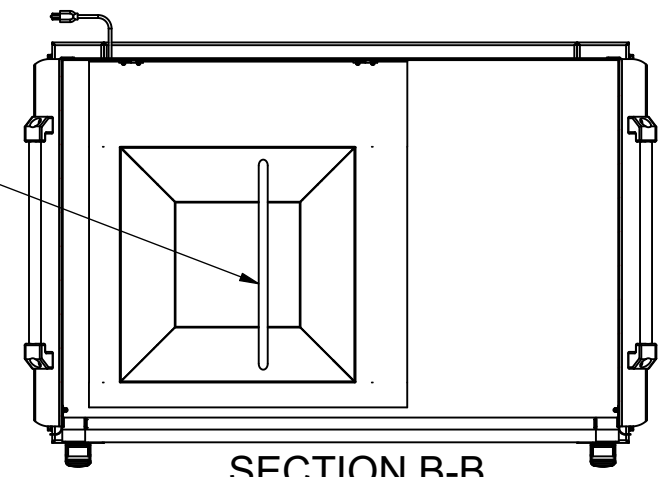

SECTION B-B
WORK SURFACE

NOTE: THIS CABINET CONTAINS ELECTRONIC COMPONENTS THAT MAY CAUSE SOME GROUND FAULT CIRCUIT INTERRUPTER (GFCI) DEVICES TO INADVERTENTLY TRIP DUE TO INHERENT DESIGN DIFFERENCES. USE AT YOUR OWN RISK.

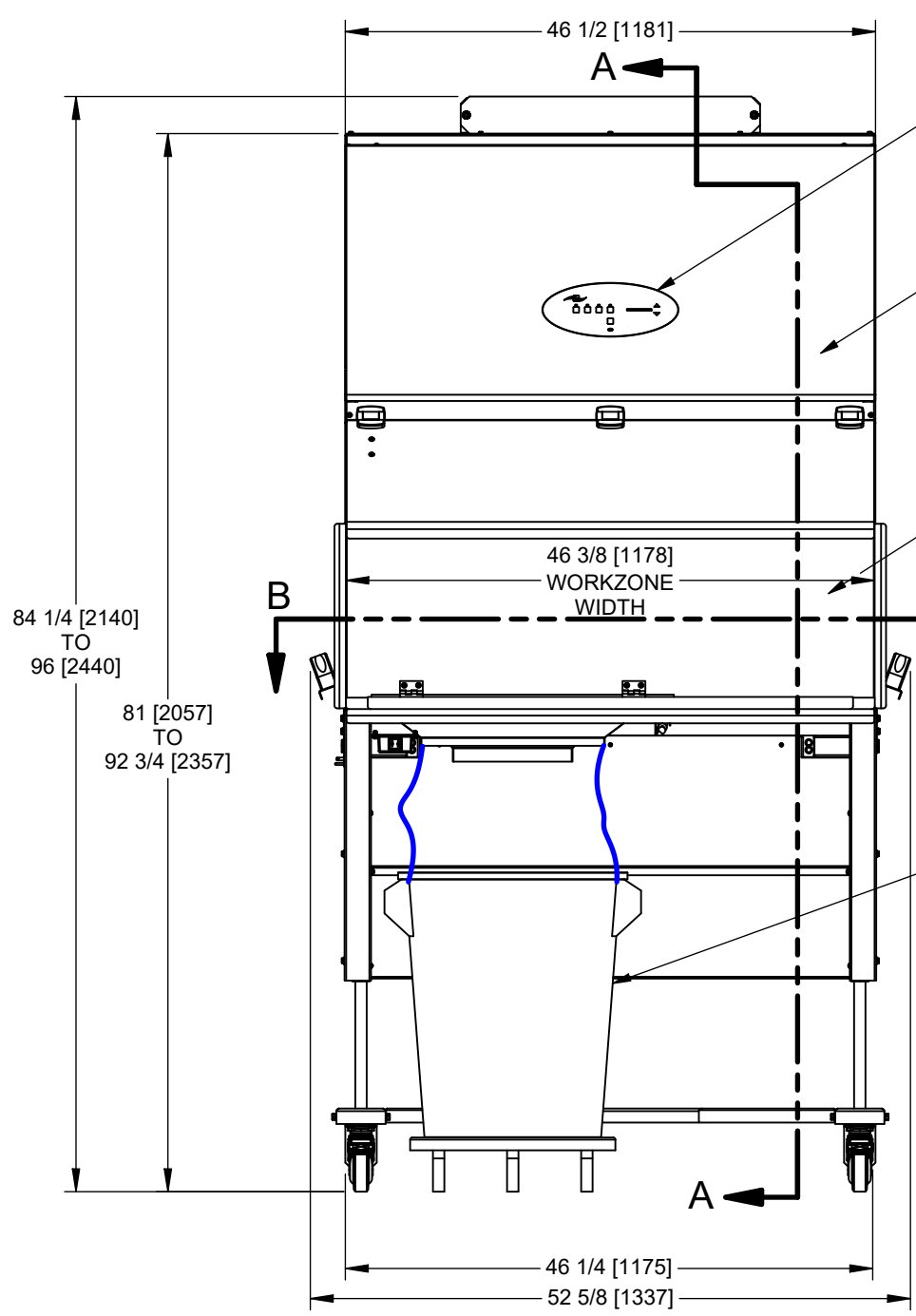

CONTROL PANEL
AEROMAX CONTROL SYSTEM
PRESSURE FLOW CONTROL SYSTEM
AIRFLOW CONTROL
BLOWER SWITCH
LIGHT SWITCH
SYSTEM DIAGNOSTICS

PAINTED EXTERIOR PANELS
AIRFLOW MODULE / CONTROL BOX

SST WORKZONE

20 GALLON [76 LITER] WASTE RECEPTACLE ON CASTERED BASE

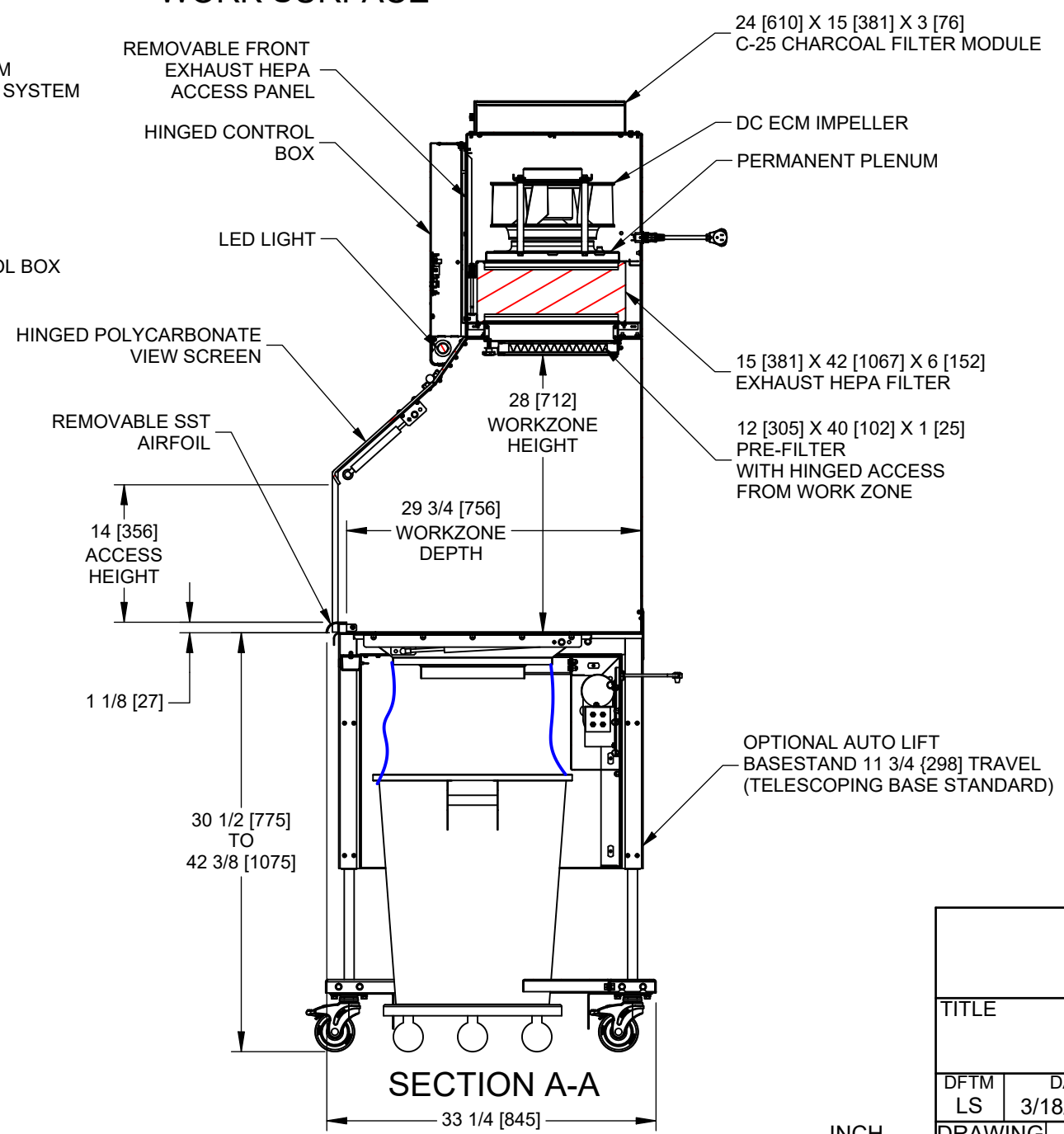

SECTION A-A

INCH
MILLIMETER

TITLE					
NU-608-400 Auto Lift Base Specification Drawing					
DFTM	DATE	CHKD	SHEET	1	OF 1
LS	3/18/2021	MSS			
DRAWING NUMBER			CD-000109		B