

REV	CO	DESCRIPTION	DATE	DFTR	CHKD
B	001593	ADDED NOTE	11/30/2022	RN	DF

POWER CORD  
NEMA (5-15P)  
IEC AUTO-LOCK  
CONNECTION

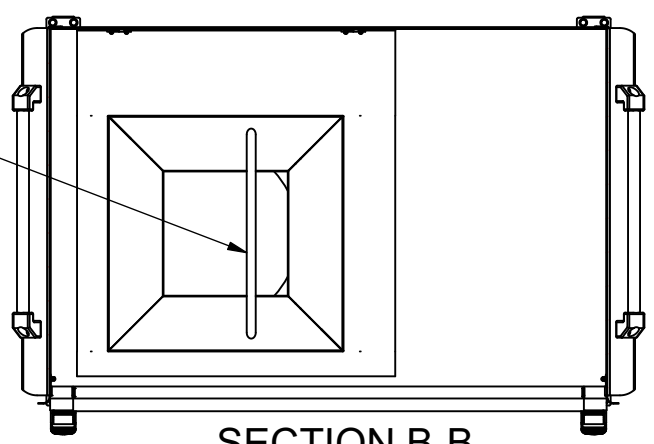

PNEUMATIC LIFT  
HINGED WORK SURFACE  
BAG ACCESS W/BANG BAR

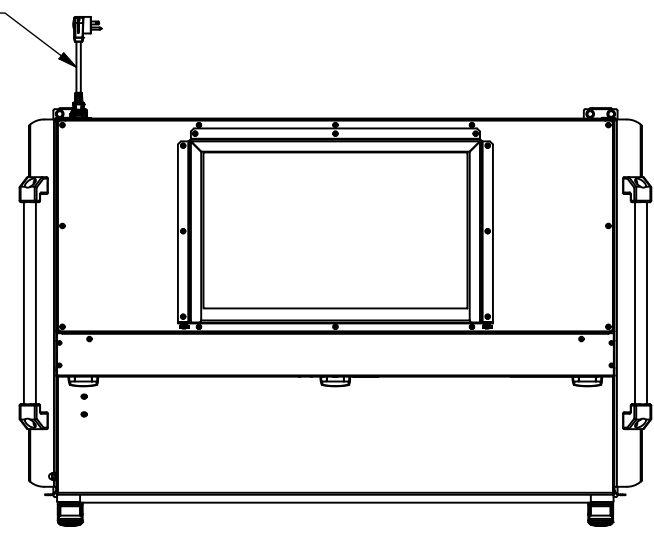

SECTION B-B  
WORK SURFACE

NOTE: THIS CABINET CONTAINS ELECTRONIC COMPONENTS THAT MAY CAUSE SOME GROUND FAULT CIRCUIT INTERRUPTER (GFCI) DEVICES TO INADVERTENTLY TRIP DUE TO INHERENT DESIGN DIFFERENCES. USE AT YOUR OWN RISK.

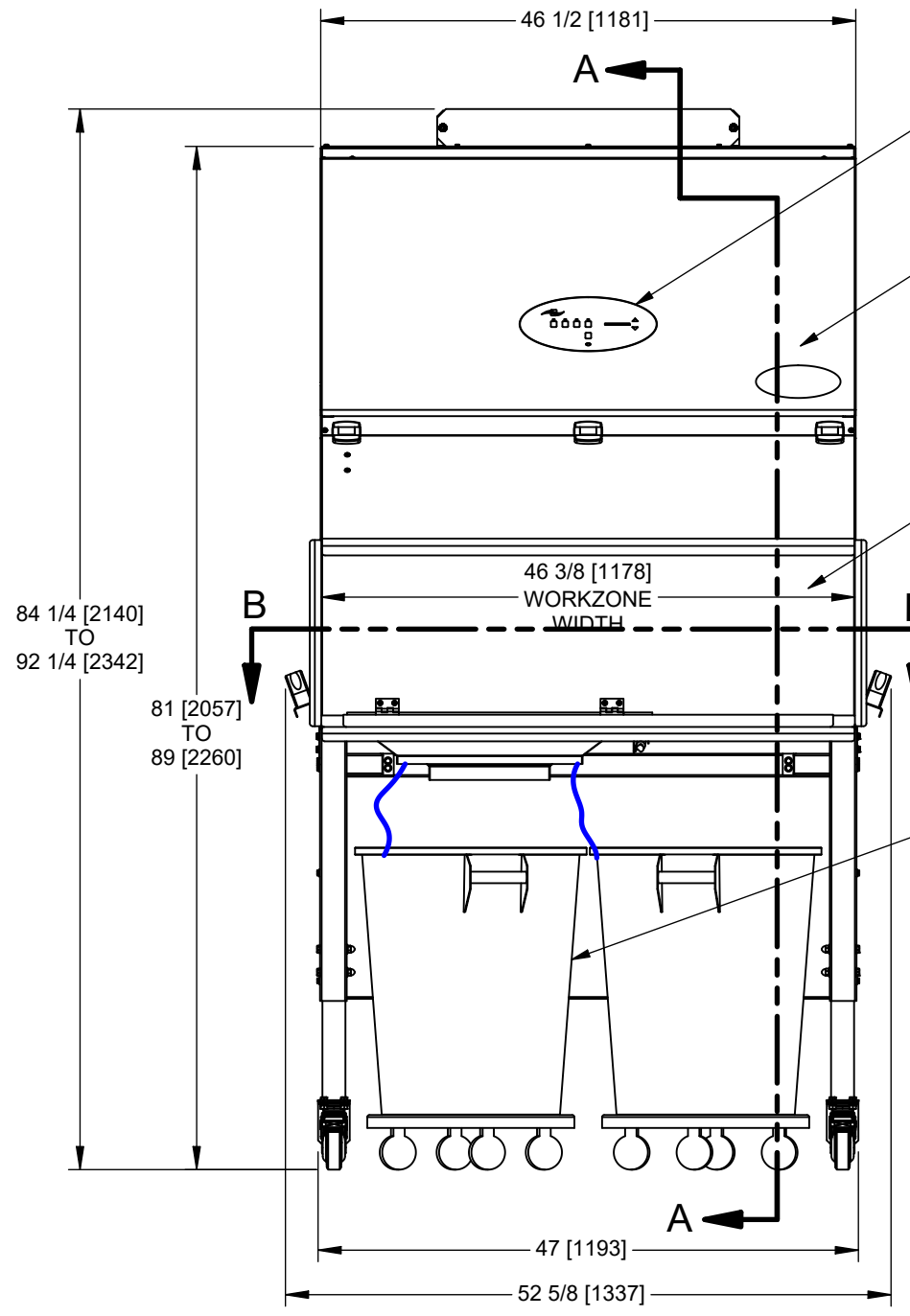

CONTROL PANEL  
AEROMAX CONTROL SYSTEM  
PRESSURE FLOW CONTROL SYSTEM  
AIRFLOW CONTROL  
BLOWER SWITCH  
LIGHT SWITCH  
SYSTEM DIAGNOSTICS

PAINTED EXTERIOR PANELS  
AIRFLOW MODULE / CONTROL BOX

SST WORKZONE

20 GALLON [76 LITER]  
WASTE RECEPTACLE  
ON CASTERED BASE

REMOVABLE FRONT  
EXHAUST HEPA  
ACCESS PANEL

HINGED CONTROL  
BOX

LED LIGHT

HINGED POLYCARBONATE  
VIEW SCREEN

REMOVABLE SST  
AIRFOIL

14 [356]  
ACCESS  
HEIGHT

1 1/8 [27]

30 1/2 [775]  
TO  
38 1/2 [978]

SECTION A-A

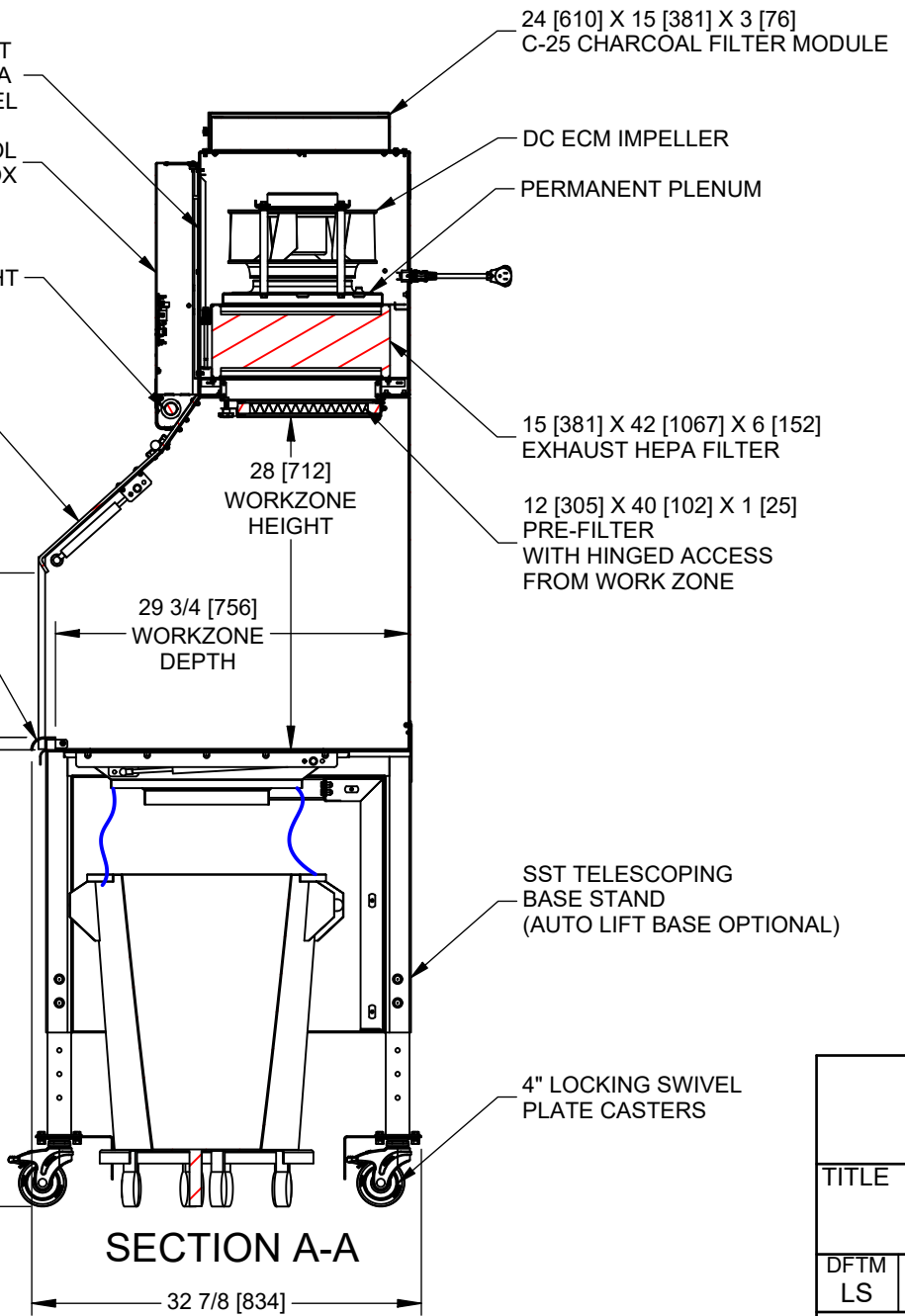

INCH  
MILLIMETER

TITLE NU-608-400 Telescoping Base Specification Drawing					
DFTM LS	DATE 3/18/2021	CHKD MSS	SHEET 1	OF 1	
DRAWING NUMBER				CD-000105	
					B