

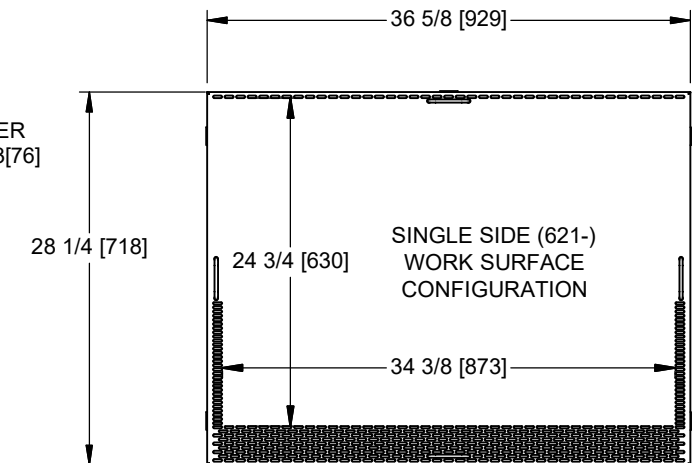

| REV | CO | DESCRIPTION | DATE | DFTR | CHKD |
|-----|--------|------------------------|------------|------|------|
| A | 002417 | RELEASED TO PRODUCTION | 09/12/2023 | RN | DF |

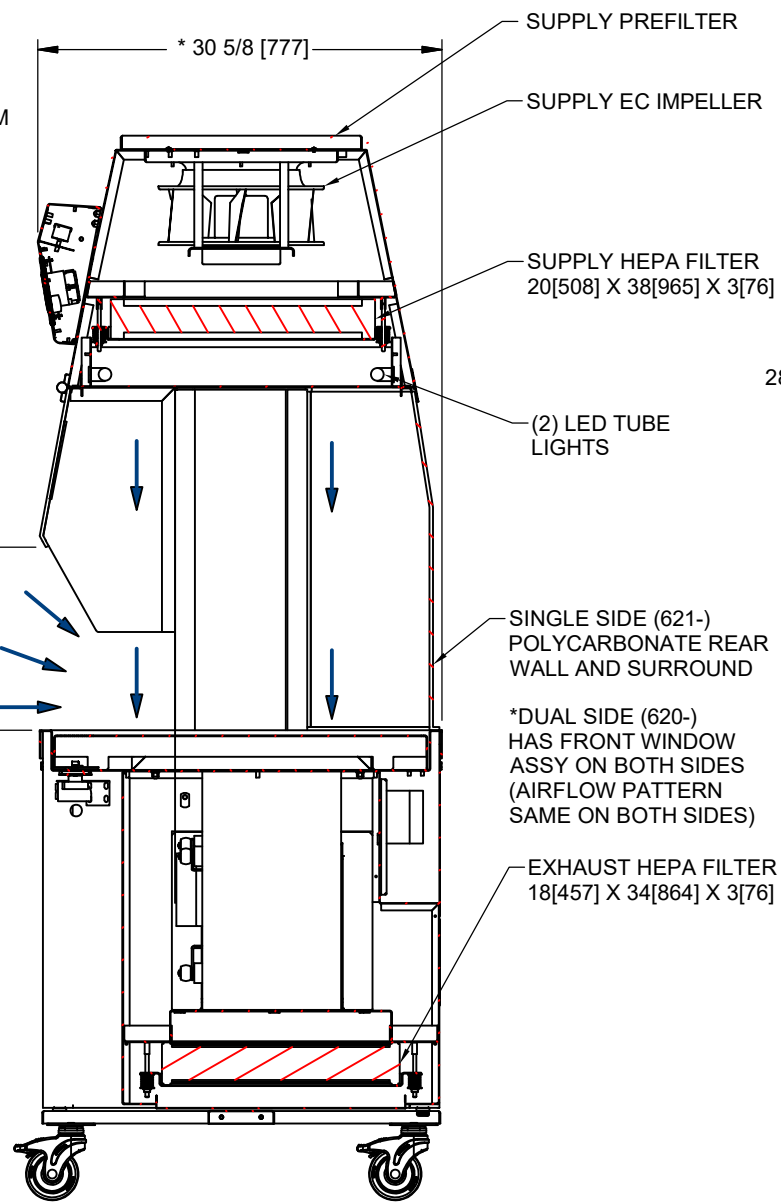
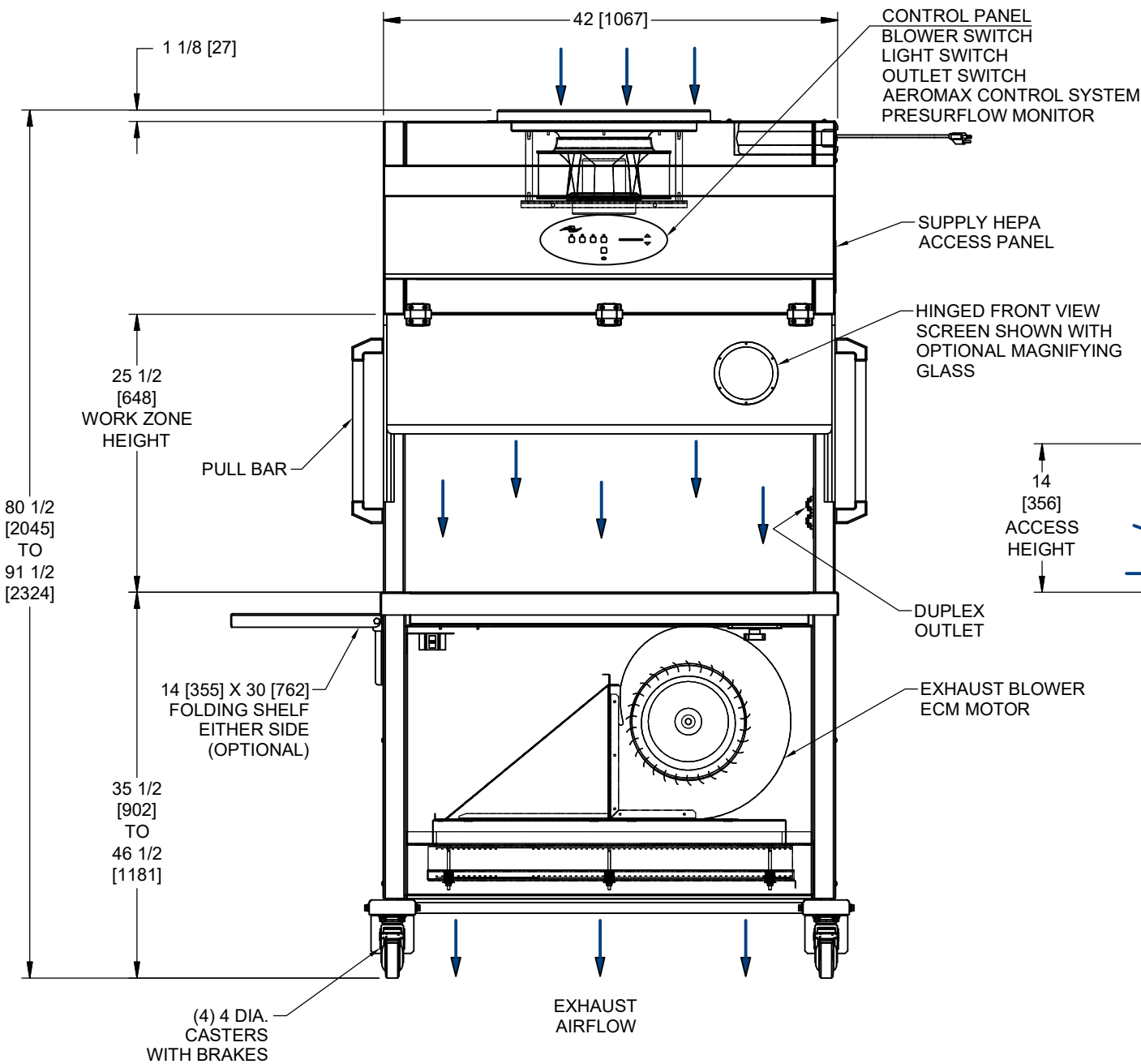
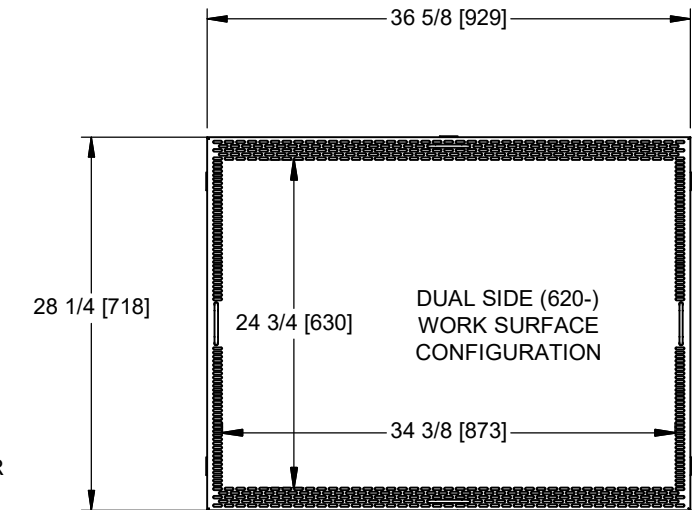
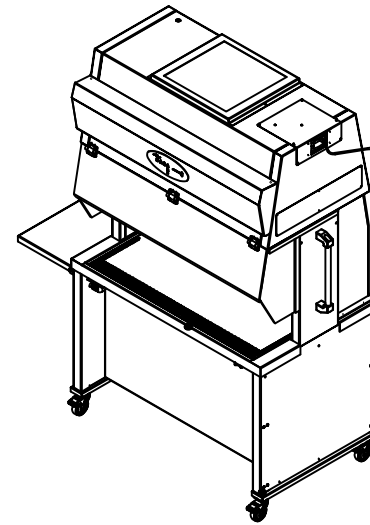
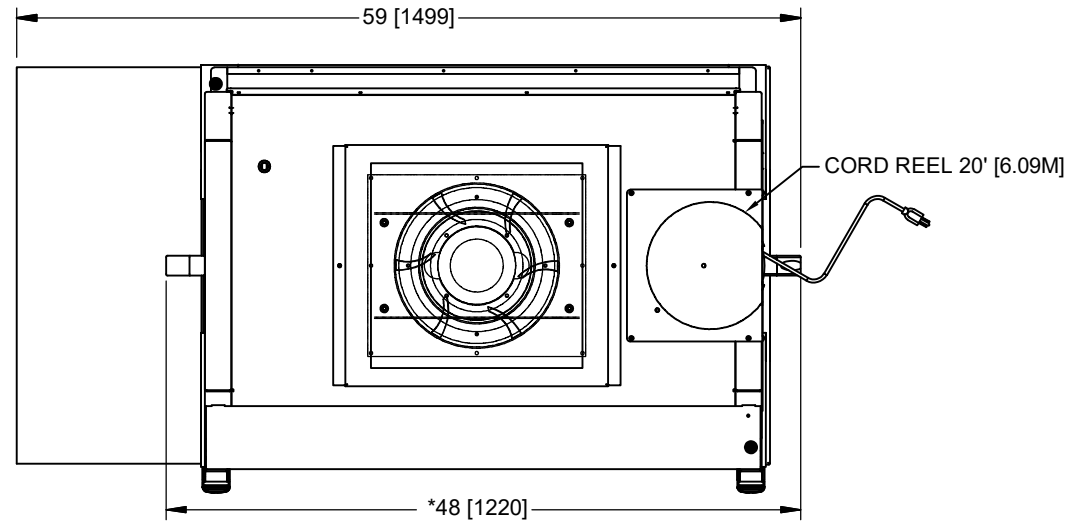

NOTE: THIS CABINET CONTAINS ELECTRONIC COMPONENTS THAT MAY CAUSE SOME GROUND FAULT CIRCUIT INTERRUPTER (GFCI) DEVICES TO INADVERTENTLY TRIP DUE TO INHERENT DESIGN DIFFERENCES. USE AT YOUR OWN RISK.

* OVERALL DIMENSIONAL TOLERANCE ±1/4 [6.35]
ALL OTHER DIMENSIONS ±1/8 [3.17]

INCH
MILLIMETER



TITLE
NU-620/621-300E SPECIFICATION DRAWING

| | | | | | | | | | |
|----------------|----|-----------|-----------|------|----|-------|---|----|---|
| DFTR | RN | DATE | 8/29/2023 | CHKD | DF | SHEET | 1 | OF | 1 |
| DRAWING NUMBER | | CD-000171 | | | | | | A | |